

# SERIE STRONG

STRONG2/10/1230, STRONG2F/10/1230, STRONG2/20/1230, STRONG2F/20/1230,  
STRONG3/20/3234, STRONG3/40/3234,  
STRONG4/50/3234, STRONG4/75/3234, STRONG4/100/3234, STRONG4/150/3234

**BOMBA SUMERGIBLE PARA EFLUENTES (AGUAS RESIDUALES )  
Y LODOS (AGUAS NEGRAS)**

FICHA TÉCNICA



# SERIE STRONG

STRONG2/10/1230, STRONG2F/10/1230, STRONG2/20/1230, STRONG2F/20/1230, STRONG3/20/3234, STRONG3/40/3234, STRONG4/50/3234, STRONG4/75/3234, STRONG4/100/3234, STRONG4/150/3234

## ESPECIFICACIONES

ALTAMIRA STRONG es una gama de bombas profesionales, diseñadas y construidas para cumplir con los requerimientos más exigentes del mercado.

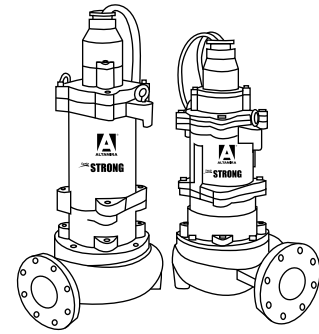

### APLICACIONES

- Aguas de infiltración y pluviales
- Evacuación de aguas fecales y residuales
- Fosas sépticas
- En general, aguas con carga de sólidos

### CARACTERÍSTICAS DE CONSTRUCCIÓN

- **Cuerpo**  
STRONG2, STRONG2F, STRONG3 y STRONG4 carcasa tipo voluta para una máxima eficiencia, fabricada en hierro fundido
- **Impulsor:**  
STRONG2: tipo Vortex, construido en hierro  
STRONG2F, STRONG3: semiabierto, construido en hierro  
STRONG4: diseño cerrado para una alta eficiencia, construido en hierro
- **Sello mecánico:**  
STRONG2, STRONG2F, y STRONG3: cerámica/carbón  
STRONG4: doble sello de carburo de silicio, carbón/vitón
- **Eje en acero inoxidable 430**
- **Cable:**  
STRONG2, STRONG2F y STRONG3: incluye 6 m de cable sumergible tomacorriente  
STRONG4: Incluye 10 metros de cable sumergible tomacorriente  
STRONG4: cuenta con dos sensores para protección contra humedad y temperatura (protegiendo así el motor y sello mecánico)
- **Tornillería en acero inoxidable**

### Motor

- Asíncrono refrigerado por inmersión en aceite, servicio continuo (cuando la bomba está totalmente sumergida).
- STRONG2: dos polos (3450 rpm)
- STRONG2F, STRONG3 y STRONG4: cuatro polos (1750 rpm)
- STRONG2 Y 2F: aislamiento clase F
- STRONG3 Y STRONG4: aislamiento clase H
- STRONG2 y STRONG2F: con protector térmico incluido
- Protección: IP68

### DESCRIPCIÓN DEL CÓDIGO

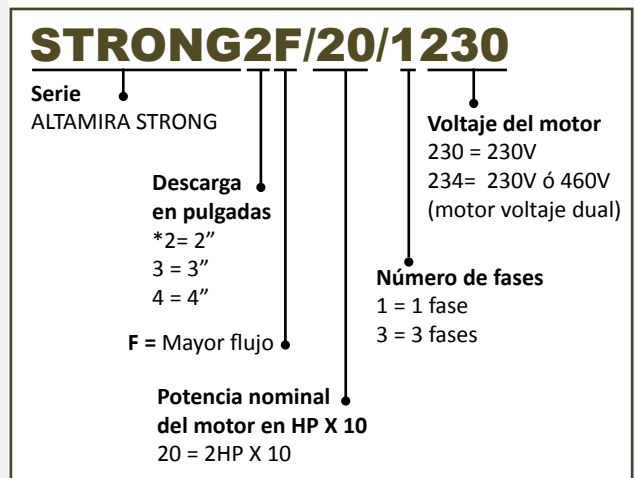

\*Nota: Los modelos STRONG2F cuentan con descarga en 3"

## CURVAS DE OPERACIÓN

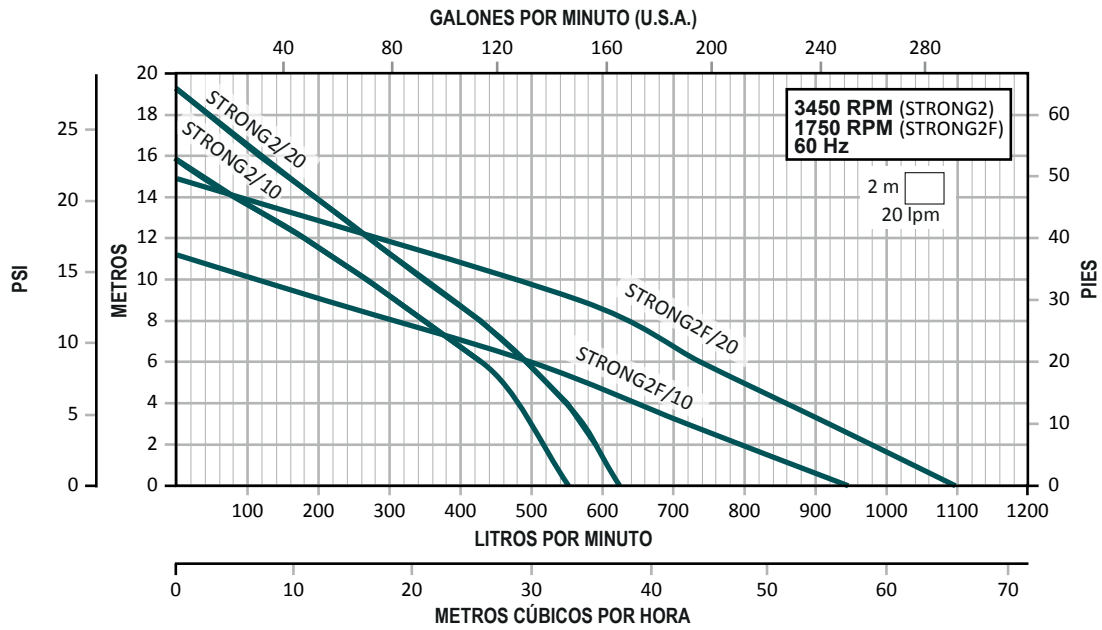

## TABLA DE ESPECIFICACIONES

CÓDIGO	HP	KW	FASES X VOLTS	AMP.	PASO DE SÓLIDOS EN SUSPENSIÓN (pulgadas)	CARGA EN METROS (psi)							
						2	4	6	8	10	12	14	16
						(2.8)	(5.6)	(8.5)	(11.3)	(14.2)	(17)	(19.8)	(22.7)
						GASTO (litros por minuto)							
STRONG2/10/1230	1	.75	1 X 230	12	2	505	465	413	345	268	180	78	
STRONG2F/10/1230				10.8		790	650	490	310	110			
STRONG2/20/1230	2	1.5		15		583	550	495	430	350	270	198	118
STRONG2F/20/1230				16.7		975	855	738	639	480	308	88	

## DIMENSIONES Y PESOS

CÓDIGO	DIMENSIONES						PESO (kg)
	mm					pulgadas	
	A	B	C	D	E	F	
STRONG2/10/1230	360.6	261.6	140	508	203.2	2" NPT	35
STRONG2F/10/1230	403	294.6		563.8	563.8	3" NPT	
STRONG2/20/1230	360.6	261.6	140	508	203.2	2" NPT	38
STRONG2F/20/1230	403	294.6		563.8	563.8	3" NPT	

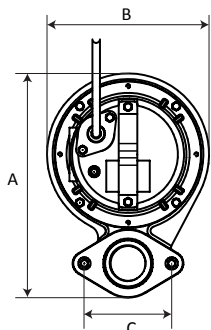

STRONG2/10, STRONG2/20

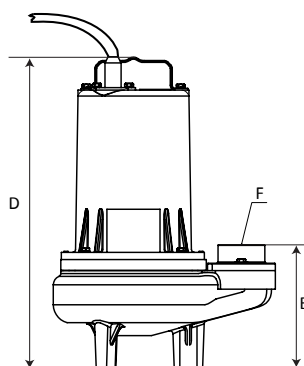

STRONG2F/10, STRONG2F/20

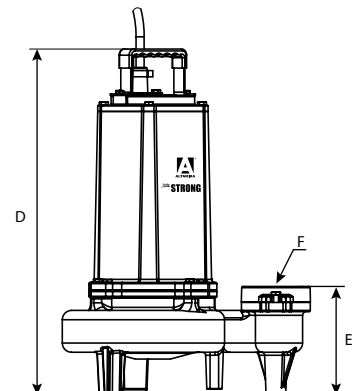
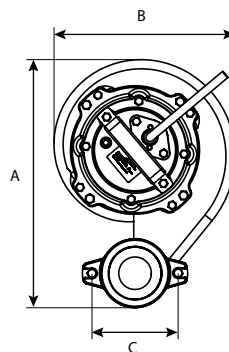

## CURVAS DE OPERACIÓN

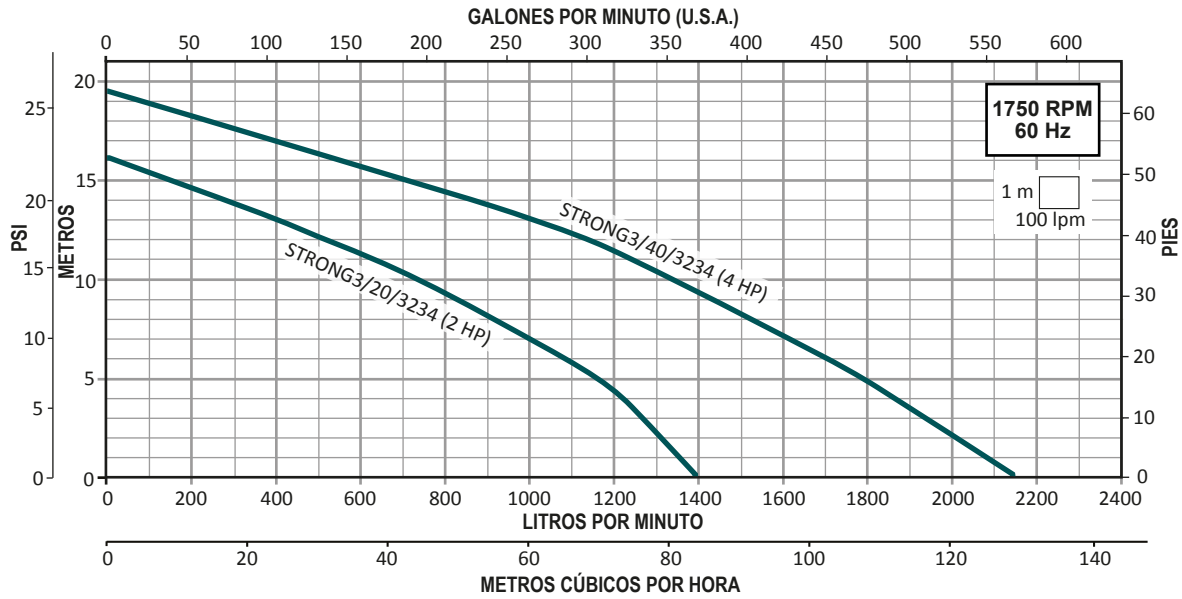

## TABLA DE ESPECIFICACIONES

CÓDIGO	HP	KW	*FASES X VOLTS	AMP.	PASO DE SÓLIDOS EN SUSPENSIÓN (pulgadas)	CARGA EN METROS (psi)						
						3	6	9	12	15	18	
						(4.2)	(8.5)	(12.7)	(17)	(21.3)	(25.5)	
							GASTO (litros por minuto)					
STRONG3/20/3234	2	1.5	3 x 230 ó 460	20 / 10	2.5"	1280	1080	810	500			
STRONG3/40/3234	4	2.9		23.6 / 11.8		1920	1700	1415	1120	700		

\*Preconectadas para trabajar en un voltaje de 230 trifásico

## DIMENSIONES Y PESO

CÓDIGO	DIMENSIONES						PESO (kg)
	(mm)					(pulgadas)	
	A	B	C	D	E	F	
STRONG3/20/3234	425.4	56.8	317.5	666.7	250.8	3" NPT	75
STRONG3/40/3234							

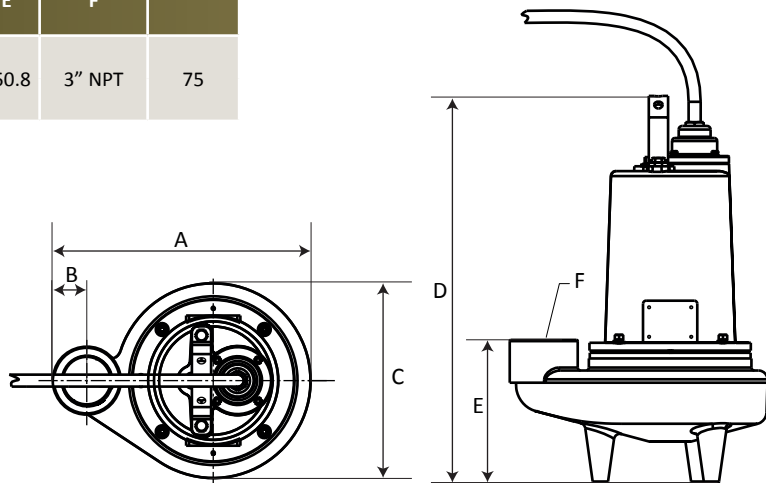

## CURVAS DE OPERACIÓN

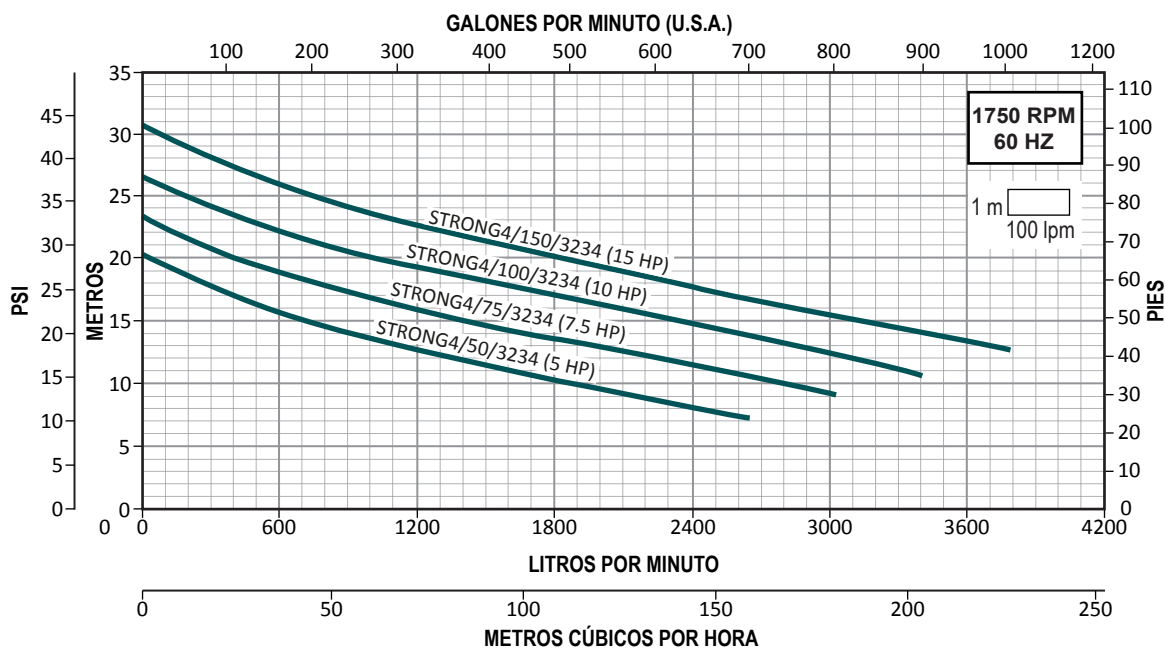

## TABLA DE ESPECIFICACIONES

CÓDIGO	HP	KW	*FASES X VOLTS	AMP.	PASO DE SÓLIDOS EN SUSPENSIÓN (pulgadas)	CARGA EN METROS (psi)						
						8	12	16	20	24	28	
						(11.36)	(17)	(22.7)	(28.4)	(34)	(39.7)	
							GASTO (litros por minuto)					
STRONG4/50/3234	5	3.7	3 x 230 ó 460	28/14	3"	2400	1350	550				
STRONG4/75/3234	7.5	5.5		33/16.5			2300	1150	400			
STRONG4/100/3234	10	7.46	3 x 230 ó 460	45/22.5			3100	2100	1000	300		
STRONG4/150/3234	15	11		55/27.5				2850	1800	800	300	

\*Preconectadas para trabajar en un voltaje de 230 trifásico

**DIMENSIONES Y PESOS**

CÓDIGO	DIMENSIONES									PESO (kg)
	(mm)								(pulgadas)	
	A	B	C	D	E	F	G	H	I	
STRONG4/50/3234	425.4	266.7	158.7	317.5	139.7	177.8	228.6	742.9	4"	126
STRONG4/75/3234	444.5	263.5	181	365	160.3	204.7		854		141
STRONG4/100/3234								152		
STRONG4/150/3234								160		

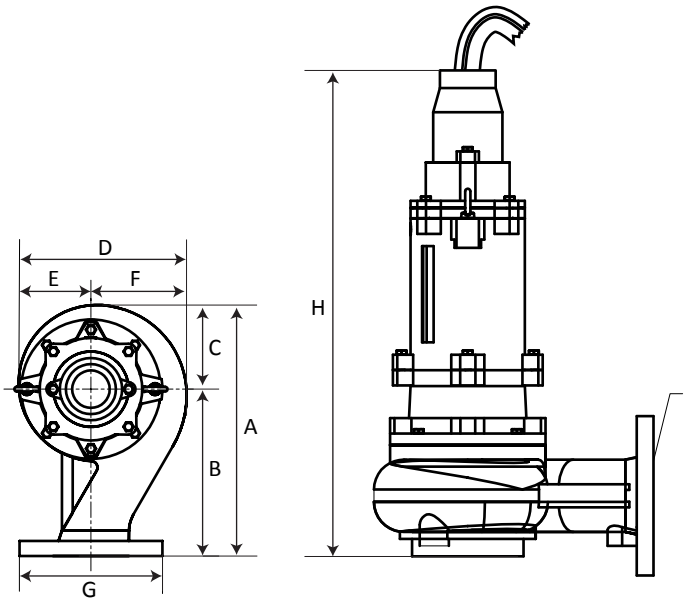

STRONG4/50/3234

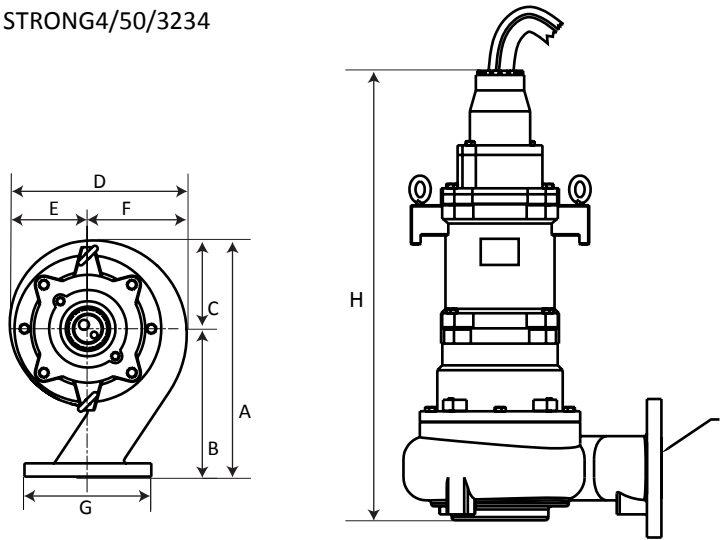

STRONG4/75/3234, STRONG4/100/3234, STRONG4/150/3234



**ALTAMIRA**



# STRONG

**BOMBA SUMERGIBLE PARA EFLUENTES Y LODOS**



